

ISTRUZIONI D'USO E MANUTENZIONE

USE AND MAINTENANCE INSTRUCTIONS

MANUEL D'UTILISATION ET D'ENTRETIEN

GEBRAUCHS- UND WARTUNGSANLEITUNG

INSTRUCCIONES DE USO Y MANTENIMIENTO

GEBRUIKS-EN ONDERHOUDSAANWIJZING

ИНСТРУКЦИИ ПО ЭКСПЛУАТАЦИИ

NÁVOD K POUŽITÍ

INSTRUÇÕES DE USO E MANUTENÇÃO

INSTRUKCJA OBSŁUGI I KONSERWACJI

User instructions

Thank you for choosing one of our products. We hope you will get the very best performance from this appliance.

Therefore we would ask you to carefully comply with the the suggestions and instructions in this manual for proper use of our products.

The manufacturer shall not be held liable for damage to persons and property which is due to poor or incorrect installation of the appliance.

The manufacturer reserves the right to modify its products as deemed fit without prior notice.

Technical characteristics

This appliance complies with circular EEC concerning limitation of radio and electrical disturbances For the parts that will come in to contact with food products, this appliance is compliant with 89/109/EEC.

Dimensions:

Height: 460 mm

Width: 597 mm

Depth: 570 mm

Volume:

Gross: 43 dm³

Net: 37 dm³

Power supply voltage: 220-240V~ 50/60Hz

User Instructions

Any work on the appliance must be carried out with the appliance disconnected from the electrical power supply.

Attention: earth connection is required by law.

During operation the oven gets very hot. Keep children away. Do not touch the heating elements on the inside of the oven.

Do not use steam cleaners to clean the oven.

Do not use the appliance to heat the room.

The manufacturer will in no way be held liable if accident prevention procedures are not observed.

The manufacturer shall not be held liable for damage to persons or property due to poor or incorrect maintenance of the appliance.

The manufacturer reserves the right to make any modifications to its products which it feels are necessary or useful without any prior notice.

Packaging (e.g. paper, polystyrene) may be hazardous to children (danger of suffocation). Keep packaging out of the reach of children.

The appliance is to be used by adults who are familiar with these instructions.

Children are often not capable of recognizing the risks connected with use of the appliance. Please supervise children properly and do not let them play with the appliance.

Disabled people must be assisted by able adults.

It is not permitted to modify, tamper with or attempt repairs on the appliance, especially with tools (screwdrivers and the like) either inside or outside the appliance. Repairs must only be carried out by authorized personnel, especially on the electrical parts.

Inappropriate repair work may cause serious accidents, damage the appliance and equipments and lead to improper operation.

Appliances repaired in technical service centres must undergo routine testing, especially the continuity of the earth circuit.

This product was designed for household use.

The manufacturer shall not be held liable for damage to persons or property due to incorrect installation, or improper, wrong or inappropriate use of the appliance.

In the event of a breakdown or if indispensable repairs are required, contact customer services.

If the oven is visibly damaged, do not use it. Unplug it and contact customer service. As soon as an operating problem is discovered, the oven must be unplugged. Make sure that the power cord of electrical appliances is not crushed by the oven door. The electrical insulation could be damaged. If the power cord has been damaged, it must be replaced by customer services department prevent possible danger.

Before closing the oven door, make sure there are no foreign objects or pets inside the oven.

Do not place heat-sensitive or flammable materials in the ovens such as detergents, oven sprays, etc.

During operation the oven gets very hot. It remains hot for a long time, even after it has been turned off. It cools slowly until it reaches room temperature. Wait for a sufficient length of time before doing anything like cleaning the oven.

When the oven door is opened, steam and water droplets may come out. If the oven contains steam, it is not advisable to put your hands inside of it. Hot grease and fat catch fire easily.

It is dangerous to heat oil in the oven to cook meat and this should be avoided. Never try to put out a grease fire using water (this could cause an explosion). Put out the flames with wet cloths.

The grill, the shelves and the cooking containers become very hot. When using or caring for the oven, do not place the fingers in the hinges, to prevent crushing and other injuries

Use care especially if children are present.

Leave the door open only in the ajar position.

If the door is left open there is a danger of tripping.

Do not sit or lean on the door and do not use it as a worktop.

The oven is equipped with a cooling fan that comes on when the cooking cycle is selected. It creates a slight air flow that exits from the vent under the control panel. It shuts down 10-30 minutes after the oven is switched off (depending on oven temperature).

INSTRUCTIONS FOR INSTALLATION OF THE UNIT

All tasks involved in installing the appliance must be carried out by a skilled professional. Any work is to be performed with the appliance unplugged.

Electrical connection:

make sure that the voltage corresponds to that indicated on the label on the side. The oven must be connected using a cable with a minimum cross-section of 1.5 mm on the rear, and with an omni-polar switch compliant with current standards with a distance of aperture between contacts of at least 3 mm.

Attention: earth connection is required by law.

The manufacturer will in no way be held liable if accident prevention standards are not observed.

Insertion into the furniture unit:

The appliance can be inserted either under a worktop or into a column. In either case comply with the dimensions shown in figures 1 and 2.

For column installation, in order to ensure proper ventilation, it is very important to provide an opening of at least 85-90mm as shown in figure 1.

The oven is secured to the furniture unit by four screws "A" located in the holes of the perimeter frame (see fig. 1).

Do not use the door as a lever when installing the oven.

Do not place excessive pressure on the oven door when it is open.

Before using the oven for the first time

After unpacking the oven, installing it in the furniture unit and removing the accessories (drip pan and racks), it is advisable to run it at the highest temperature for about 20 minutes to remove any oily residues left from the manufacturing process which may cause unpleasant odours during cooking. Aerate the room while doing this. Wash the drip pan and racks with washing up liquid.

For the first few minutes that the oven is in operation, condensation may form on the front. This does not in any way compromise operation of the unit.

OVEN FUNCTIONS

Indicator light

For any position of the selector knob other than 0, the green indicator light comes on.

If the yellow indicator light is on it indicates that the thermostat is in operation.

Selector knob

This device lets you select various cooking functions.

Electronic programmer

Allows you to programme the desired cooking time.

Thermostat knob

Choose the temperature you prefer for cooking.

Turn it clockwise, selecting a temperature between 50°C and Max.

USE OF THE SELECTOR



DEFROSTING

The oven light and the green indicator light come on in the same way as other oven functions. Only the fan starts working, without the transmission of heat as the thermostat is not in operation.

The oven door must be closed. This function makes it possible to defrost foods using only about one-third of the time that would normally be required.



TRADITIONAL COOKING

Select the desired temperature. The yellow indicator light will stay on until the set temperature is reached.

Be sure to pre-heat the oven before inserting food.



FAN COOKING

This type of cooking allows even heat distribution to all parts of the oven.

It is possible to cook two different types of food (e.g. meat and fish) while using their different respective cooking times.



CENTRE GRILL

Select the desired temperature with the oven door closed.

This kind of cooking is especially suited to small amounts of food.



DOUBLE GRILL

Select the desired temperature with the oven door closed.

This type of cooking is especially suited for larger quantities of foods that require full width grilling.



FAN + GRILL

Select the desired temperature.

The action of the fan, combined with the action of the grill, allows for quick, thorough cooking of foods.

It is advisable to heat the oven for a few minutes before putting food in it.



FAN AND BOTTOM ELEMENT

Select the desired temperature.

This type of cooking is especially slow and delicate.

Table of cooking suggestions

Type of dish	Temp. °C	Cooking time in minutes	Level (from bottom)	Cycle
• Bread and biscuits				
Pizza	220	20/30	1	☺ or ☻
Bread	190/200	45/60	1	
Bread with filling	150/160	20/25	1 or 2	
White bread	175/210	25/40	1 or 2	
Biscuits	140/150	20/30	1 or 2	
• Pie and pastry				
Focaccia	175	40/45	2	☺ or ☻ or ☹
Sponge cake	190	25/35	2	
Chocolate cake	175	30/40	2	
Fruit pie	140	50/70	2	
Vol-au-vent	175	20	2	
Doughnut	180	35/45	2	
Angel cake	150	20/25	2	
Souffle	180/200	20/30	2	
Meringue	120/125	25/35	2	
• Meats				
Veal stew (1/1,5Kg)	150/160	180/210	1 or 2	☺ or ☻
Roast veal (1/1,5Kg)	150/160	120/150	1 or 2	
Meat loaf(1/1,5Kg)	180/190	90/120	1 or 2	
Lamb (leg or chop)	180/190	60/90	1 or 2	
Beef (leg or chop)	180	45/60	1 or 2	
Pork (loin or leg)	180	60/90	2	
• Game				
Roast pheasant	180	60/90	1 or 2	☺ or ☻
Venison	175	90/120	1 or 2	
• Poultry				
Chicken	170	90/120	1 or 2	☺ or ☻
Duck	175	180/200	1	
• Fish				
Fish in general	200	15/20	2	☺ or ☻

Foods to be grilled	Cooking time in minutes	
	Over	Under
Cuts of thin meat	6	4
Cuts of normal meat	8	5
Fish (e.g. trout, salmon)	15	12
Sausages	12	10
Toast	5	2

Depending on the type of food (e.g. meats, fish, poultry, etc.), you will need to turn the

food to expose both sides to the infrared rays

The data provided above is approximate. Cooking times vary based on the experience of the person using the oven and the amount and quality of the foods.

The cooking times do not include pre-heating. It is advisable to pre-heat the oven for about 15 min.

With the ventilated grill function, do not select a temperature of more than 190°C.

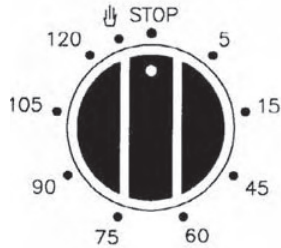

120 MINUTES CUT-OFF TIMER

The function of the programming timer is to turn on the oven for a pre-determined amount of time.

Operating:

After having set the oven, switch knob at the desired temperature, turn the timer knob in a clockwise direction to the desired cooking time (max. 120 minutes).

when the timer will return to position "0", a minute counter ringing will advise that the oven will automatically turn off.

Manual position:

If the cooking time is longer than the 2 hours programme, or if you wish to use the oven manually, to turn it off when you desire, turn the knob to manual position.

ELECTRONIC PROGRAMMER

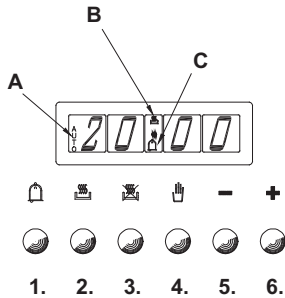

The electronic programmer is a device which groups together the following functions:

24 hours clock with illuminated display

Timer (up to 23 hours and 59 min.)

Program for automatic beginning and end of cooking

Program for semi-automatic cooking (either start or finish only).

Description of keys

1. Timer
2. Cooking time
3. End of cooking time
4. Manual position
5. Advancement of the numbers of all programs
6. Turning back of the numbers of all programs

Description of lighted symbols

- A). «AUTO» flashing:**
programmer in automatic position but not programmed.
- A). «AUTO» always lighted:**
programmer in automatic position with inserted program.
- B).** Programmer switched on.
- C).** Timer in operation.
- B). and A). both flashing:** program error

No lighted symbol except clock numbers: oven on manual setting.

Digital clock

Clock numbers show hours (0-24) and minutes.

Upon immediate hooking up of the oven or after a blackout, three zeros will flash on the programmer panel. To set the hour it is necessary to push simultaneously the **2.** + **3.** keys and AT THE SAME TIME to push the [+] **key or [-]** until you have set the exact hour.

The regulation speed depends on the pressure exercised on the [+] **[-]** keys.

Manual cooking without using the programmer

To use the oven manually (without the programmer) it is necessary to delete the flashing «**AUTO**» by touching the **1.** key.

If «**AUTO**» is still flashing (which means a cooking program is still memorized) it is necessary to delete the inserted cooking program by pushing the **1.** key until setting the clock on zero.

Automatic cooking (start and end)

1. Set the length of cooking time by touching the **2.** key.
2. Set the end of cooking time by touching the **3.** key.
3. Set temperature and cooking program by using the thermostat knob and the selector knob.

After this setting the symbol «**AUTO**» will flash, this means the oven has been programmed.

An example: cooking lasts 45 minutes and is expected to stop at 14.00.

- Push the **2.** key until having set 0.45.

- Push the **3.** key until having set 14.00.

Once having set this time, the clock hour will appear on the panel and «**AUTO**» symbol will flash permanently. This means the cooking program has been memorized.

At 13.15 h. (14.00 h. minus 45 minutes) the oven turns on automatically. During cooking time the **B.** symbol and «**AUTO**» symbol are flashing.

At 14.00 h. the oven turns off automatically, a buzzer goes on until it is stopped by pushing the key **1.**

Semi-automatic cooking

- **Setting the length of cooking time**
- **Setting the end of cooking time**

Setting the length of cooking time

Set the length of cooking time by pushing the **2.** key. The oven will turn on immediately.

«**AUTO**» and **B).** symbols will light. When the set cooking time has elapsed, the oven will turn off, a buzzer will ring until it is stopped as above described.

Setting the end of cooking time

Set the end of cooking time by pushing the **3.** key.

The oven will turn on immediately. «**AUTO**» and **B).** will light. At the set time, the oven will turn off and a buzzer will ring until it is stopped as above described. The cooking program may be seen at any moment by pushing the corresponding key.

The cooking program may be deleted at any moment by pushing the **2.** key until zero appears on the display.

Then by pushing the **4.** key the oven can work manually.

Timer = buzzer

The timer program consists only of a buzzer which may be set for a maximum period of 23 hours and 59 min.

To set the timer, push the **1.** key and, at the same time, **[+]** or **[-]** until you read the desired time on the display.

After the setting, the clock hour and the **C).** symbol will appear.

The countdown will start immediately and may be seen at any moment on the display by simply pressing the **1.** key.

At the end of the set time, the **C).** symbol will turn off and the buzzer will ring until it is stopped by pressing the **1.** key.

Please note:

An energy blackout makes the clock go to zero and deletes any set program.

After a blackout three zeros are flashing on the panel and the oven cannot be operated in this situation.

You need to press the **1.** key to stop flashing:

now you can set the clock and the oven is ready to use again.

CLEANING AND MAINTENANCE OF THE OVEN

Important: Before performing any maintenance, you must either unplug the oven or disconnect the power supply via the omni-polar switch of the electrical system.

Cleaning the oven:

- **Let the oven cool after each use** and clean it to keep burnt on residues from being repeatedly heated.
- For tough dirt, use a product specifically for oven cleaning. Follow the instructions on the container of the product.
- Clean the outside with a sponge dampened in lukewarm water.
- Do not use abrasive products, steel wool pads, electrical or steam cleaners, or flammable products.
- Do not use abrasive substances or materials to clean the glass as they may damage it.
- Wash accessories in a dishwasher or by hand using a product for oven cleaning.

ATTENTION: use protective gloves for the following tasks.

How to remove the oven door

To make it easier to clean the oven, it is possible to remove the door from the hinges as follows:

The hinges A are equipped with 2 mobile U-bolts B.

When the U-bolts B are lifted, the hinges are disconnected from their housing.

- After this, lift the door up and pull it outwards, holding the door on both sides near the hinges.

To re-install the door:

- Slide the hinges into the grooves and open the door all the way.
- Turn the mobile U-bolts to their starting position before closing the door again.

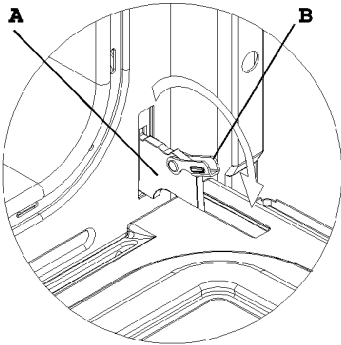

ATTENTION:

Please ensure that you do not remove the hinge locking system when you remove the door. The hinge mechanism has a very strong spring. Never immerse the door in water.

Cleaning the side rails

The side rails are to be hooked onto the wall of the oven. Slide the racks and tray provided into the side rails.

To remove the side rails press on part A as shown .

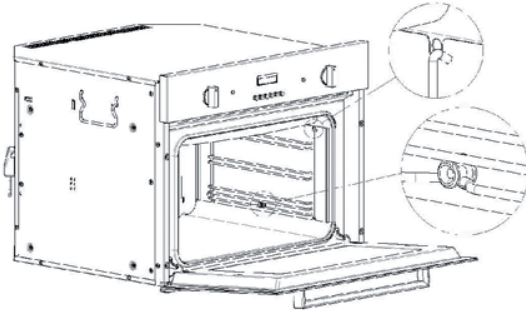

Replacement of oven lamp

- Disconnect the oven from the electrical power supply.
- Use a screwdriver to remove the light cover.
- Replace the lamp
- Put the light cover back
- Restore the power supply

N.B. : use only lamps that are 25W 230V, type E-14, T 300°C.

The lamp used in this appliance is a ‘special purpose lamp’ intended only for the usage with this appliance; it is not intended for household room illumination.

